

SS-120

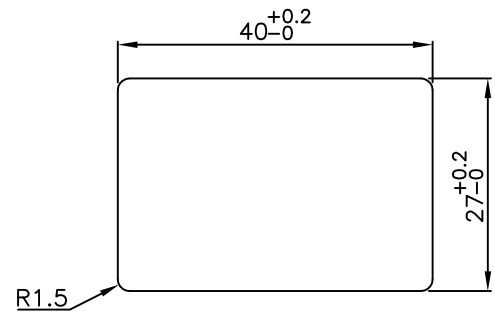

MOUNTING HOLE
PANET THICK:0.8-2.0mm

SOCKET(SS-120)	SWITCH(RF-1003)
Rating:15A 250V AC Approvals:UL/CSA Rating:10A 250V AC Approvals:VDE/SEMKO/CCC	Rating: 10GPA/250V AC 50/60Hz T85 TV-5/125V AC 50/60Hz T85 Approvals: UL/cUL Rating: 8A/80A 250V AC 1E4 T85 10(4)A 250V AC 1E4 T85 Approvals: ENEC/CQC/KTL

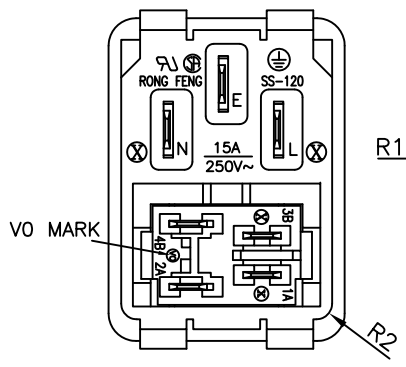
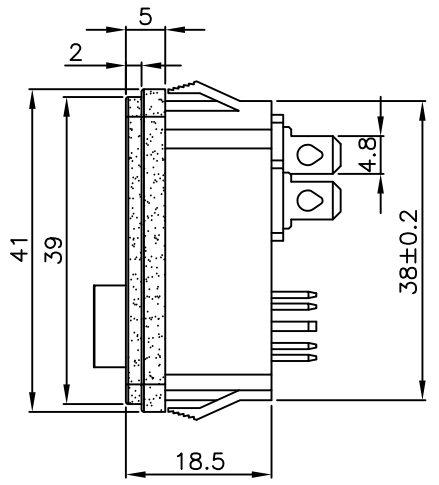
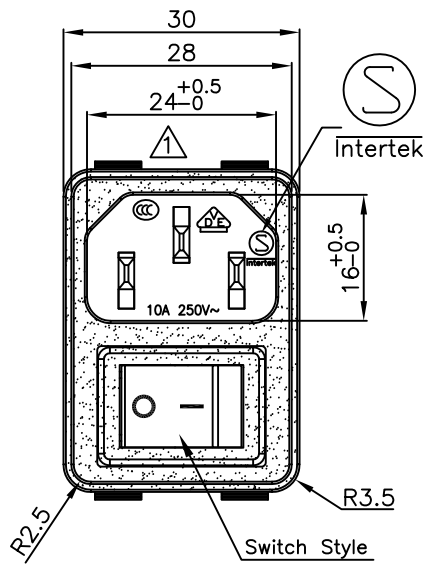
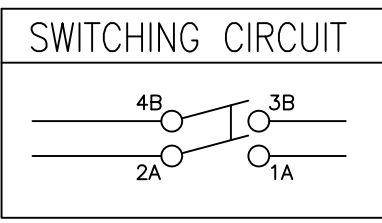
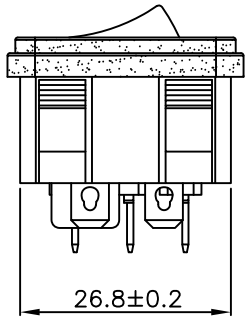

Part No.	Button Printing	Body Color	Button Color	Lamp Type	Rating	VO
SS-120-BEL3BB81		White	Black	Without Lamp	10A	
SS-120-BEL3BB81V		White	Black	Without Lamp	10A	VO
SS-120-BEL3B181V		White(移印)	Black	Without Lamp	10A	VO
SS-120-BEL3BR11	o -	White	Black	AC110V	10A	
SS-120-BEL3BR31	o -	White	Black	AC220V	10A	
SS-120-BEL3BB31		White	Black	AC220V	10A	
SS-120-BEL3BR51		White	Black	AC110V&AC220V	10A	
SS-120-BEL3BG51		White	Black	AC110V&AC220V	10A	
SS-120-BEL1BB81	o .	White	Black	Without Lamp	10A	
SS-120-BEL1BR81	o .	White	Black	Without Lamp	10A	
SS-120-BEL5BB81			Black	Without Lamp	10A	
SS-120-BEL5BB81V			Black	Without Lamp	10A	VO
SS-120-BEL6BB81		White	Black	Without Lamp	10A	
SS-120-BEL6BB81V		White	Black	Without Lamp	10A	VO
SS-120-BEL8BB81	ON/OFF	White	Black	Without Lamp	10A	
SS-120-BEL8BB81V	ON/OFF	White	Black	Without Lamp	10A	VO

NO.	DESCRIPTION	APPROVED	DATE	ANGLE	GENERAL TOLERANCE	approved	checked	designed	drawn	ALL SIZE ARE IN	MM	DRAWING NO.
5	→				GENERAL TOLERANCE	approved	checked	designed	drawn	ALL SIZE ARE IN	MM	930634
4	→				GRADATION TOLERANCE					SCALE	2:1	
3	→				X					MAT'L	**	
2	→				X.X					MATERIAL NO.		
1	© → ©				X.XX							
					±1°	RONG FENG INDUSTRIAL CO.,LTD.				SS-120-BEL		

Hvey

