

MODEL NO.

产品名称: SK12D02/169

DRAWN 制订

余丽珍

APPD. 审核

李小勤

1、RATING (额定值) : DC 50V 0.3A

2、FUNCTION (接触型式) : 1P2T

3、TIMING (时间特性) : NON-SHORTING

4、ELECTRICAL CHARACTERISTICS (电气性能规格)

ITEM 项目	TEST CONDITIONS 测试条件	PERFORMANCE 规格
4.1 CONTACT RESISTANCE 接触电阻	MEASURED AT 1KHz SMALL CURRENT (100mA OR LESS) 在 1KHz 微小电流(100mA 以下)测试.	100mΩ MAX. 100 毫欧以下
4.2 INSULATION RESISTANCE 绝缘电阻	APPLY A VOLTAGE OF 500V DC FOR 1 MIN. TO FOLLOWING PORTIONS AFTER WHICH MEASUREMENT SHALL BE MADE. (1) BETWEEN BODY AND TERMINAL. (2) BETWEEN TERMINALS. 输入 500V DC 电压 1 分钟,按以下接触方法测试: (1) 排脚相互之间。 (2) 排脚与外壳之间。	100MΩ MIN. 100 兆欧以上.
4.3 DIELECTRIC STRENGTH 耐电压	AC 500V rms (50-60Hz) FOR 1 MIN TRIP CURRENT: 0.5mA (1) BETWEEN TERMINALS. (2) BETWEEN INDIVIDUAL TERMINAL AND FRAME. 输入 AC 500V (50-60Hz) 电压, 1 分钟感度电流为 0.5mA,按以下接触方法测试: (1) 排脚相互之间 (2) 排脚与外壳之间.	WITHOUT DAMAGE TO PARTS ARCING OR BREAKDOWN ETC 没有绝缘破坏等异常

5、MECHANICAL CHARACTERISTICS (机械性能规格)

ITEM 项目	TEST CONDITIONS 测试条件	PERFORMANCE 规格
5.1 OPERATING FORCE 作动力	MEASUREMENT SHALL BE MADE AT THE NEAREST POINT OF THE COMPONENT OR AT THE POINT 3mm FROM THE TIP OF THE ACTUATOR (KNOB). 在距离胶柄前端 3mm 作测定点.	250gf ± 100gf
5.2 TERMINAL STRENGTH 端子强度	A STATIC LOAD OF (500gf) SHALL BE APPLIED TO THE TERMINAL FOR 15 SEC, IN ANY DIRECTON. 在排脚前端任意一个方向加 500gf 力度测试,时 间为 15 秒.	MECHANICAL AND ELECTRICAL CHARACTERISTICS SHALL BE SATISFIED WITHOUT LOOSENESS OF ACTUATOR. 在端子中没有裂开,松动等 异常,满足于机械、电器性 能。
5.3 DISPLACEMENT OF ACTUATOR (KNOB) 柄强度	A STATIC LOAD OF 10N (1Kg) SHALL BE APPLIED TO THE TOP OF THE ACTUATOR (KNOB) AND THEN DESPLACEMENT SHALL BE MEASURED TO THE DIRECTION OF THE ARROW. 在柄的前端施加 1Kg 的力度,位移应沿印记的方向上定.	THE LEVER SHALL HAVE NO SERIOUS DEFORMATION AND FUNCTION IS NORMALLY. 柄部无严重变形,可以正常工作

## 6、ENDURANCE CHARACTERISTICS (耐久性) :

ITEM 项目	TEST CONDITIONS 测试条件	PERFORMANCE 规格									
6.1 LIFE TEST 寿命试验	WITHOUT LOAD: AN ACTUATOR SHALL BE SUBJECT TO 10,000 CYCLES AT A SPEED OF 15 TO 18 CYCLES FOR 1 MIN. 无负荷: 操作者以每分钟 15—18 回的频率作 10,000 回之无负荷测试。	(1) CONTACT RESISTANCE(接触电阻) 100mΩ MAX. 100 毫欧以下。 (2) INSULATION RESISTANCE(绝缘电阻) 50MΩ MIN. 50 兆欧以上。 (3) WITHSTAND VOLTAGE(耐电压) AC 500V, 1 MINUTE. AC 500V 1 分钟 (4) OPERATING FORCE(作动力) ±30% INITIAL VALUE. 变化范围初始值±30% (5) WITHOUT DAMAGE TO PARTS ARCING OR BREAKDOWN ETC. (测试后外表无损伤,并且满足机械性能)									
6.2 SOLDERABILITY TEST 可焊性试验	THE TOP OF THE TERMINALS SHALL BE DIPPED 2mm IN THE SOLDER BATH OF 230±5℃ FOR 3±0.5 SECONDS. 端子顶部被浸入锡焊池中 2mm 深,温度为 230±5℃,时间为 3±0.5 秒。	THE AREA OF SOLDERING SHOULD BE OVER 75% 焊接面积要有 75%以上。									
6.3 RESISTANCE TO SOLDERING HEAT TEST 耐焊性试验	(1). TEMPERATURE AND IMMERSING TIME 温度及浸锡时间 <table border="1" data-bbox="349 1272 1037 1570"> <thead> <tr> <th></th> <th>TEMPERATURE 温度 (℃)</th> <th>TIME 时间 (S)</th> </tr> </thead> <tbody> <tr> <td>DIP SOLDERING 浸锡</td> <td>260±5</td> <td>3±1</td> </tr> <tr> <td>MANUAL SOLDERING 手焊</td> <td>360±10</td> <td>3±1</td> </tr> </tbody> </table> (2) IMMERSION DEPTH: IMMERSION DEPTH UP TO THE SURFACE OF THE BOARD THICKNESS OF PRINTED WIRING BOARD 1.6mm. 浸锡深度: 浸锡深度至基板(PCB)表面,基板厚度为 1.6mm。		TEMPERATURE 温度 (℃)	TIME 时间 (S)	DIP SOLDERING 浸锡	260±5	3±1	MANUAL SOLDERING 手焊	360±10	3±1	THERE SHALL BE NO DEFORMATION OR CRACKS IN MOLDED PART. 外观无异常,满足于机械、电器性能。
	TEMPERATURE 温度 (℃)	TIME 时间 (S)									
DIP SOLDERING 浸锡	260±5	3±1									
MANUAL SOLDERING 手焊	360±10	3±1									
6.4 COLD TEST 耐冷试验	THE SWITCH SHALL BE STORED AT A TEMPERATURE OF -25±3℃ FOR 48 HOURS. THEN THE SWITCH SHALL BE MAINTAINED AT STANDARD ATMOSPHERIC CONDITIONS FOR 1 HOUR AFTER WHICH MEASUREMENT SHALL BE MADE. 放置在温度-25±3℃中 48 小时后,再将放置在常温常湿的环境中 1 小时后进行测试。										

ITEM 项目		TEST CONDITIONS 测试条件	PERFORMANCE 规格
6.5	HEAT TEST 耐热试验	THE SWITCH SHALL BE STORED AT A TEMPERATURE OF $70\pm 2^{\circ}\text{C}$ FOR 48 HOURS. THEN THE SWITCH SHALL BE MAINTAINED AT STANDARD ATMOSPHERIC CONDITIONS FOR 1 HOUR AFTER WHICH MEASUREMENT SHALL BE MADE. 放置在温度 $70\pm 2^{\circ}\text{C}$ 中测试 48 小时后, 再将放置在常温常湿的环境中 1 小时后进行测试.	THERE SHALL BE NO DEFORMATION OR CRACKS IN MOLDED PART. 外观无异常, 满足于机械、电器性能.
6.6	HUMIDITY TEST 潮湿试验	THE SWITCH SHALL BE STORED AT A TEMPERATURE OF $40\pm 2^{\circ}\text{C}$ AND A HUMIDITY OF 90% TO 95% FOR 96 HOURS. THEN THE SWITCH SHALL BE MAINTAINED AT STANDARD ATMOSPHERIC CONDITION FOR 1 HOUR AFTER WHICH MEASUREMENT SHALL BE MADE. 放置 $40\pm 2^{\circ}\text{C}$ 的相对湿度为 90%~95% 环境中 96 小时后, 再将放置在常温常湿的环境中 1 小时后进行测试.	
6.7	STANDARD ATMOSPHERIC CONDITIONS 测试标准状态	UNLESS OTHERWISE SPECIFIED. THE STANDARD RANGE OF ATMOSPHERIC CONDITIONS FOR MAKING MEASUREMENTS AND TESTS ARE AS FOLLOWS: (1) AMBIENT HUMIDITY: $5^{\circ}\text{C}$ TO $35^{\circ}\text{C}$ (2) RELATIVE HUMIDITY: 45% TO 85% (3) AIR PRESSURE : 86Kpa TO 106Kpa 在没有指定的情况下测试温度、湿度、气压如下: (1) 温度为 $5^{\circ}\text{C}$ — $35^{\circ}\text{C}$ . (2) 湿度为 45%—85%. (3) 气压为 86Kpa—106Kpa.	
6.8	PRACTICAL TEMPERATURE RANGE 使用温度范围	$-16^{\circ}\text{C}$ ~ $+60^{\circ}\text{C}$ . 在 $-16^{\circ}\text{C}$ ~ $+60^{\circ}\text{C}$ 温度内使用.	



CAD FILE:

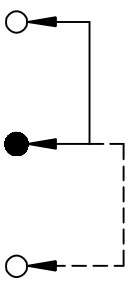
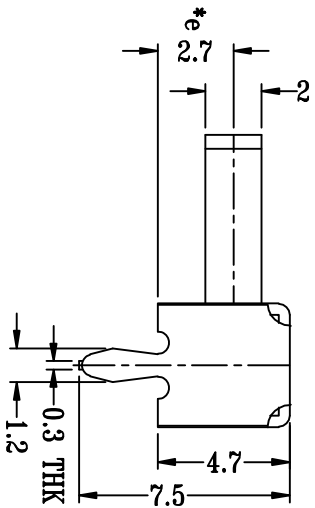
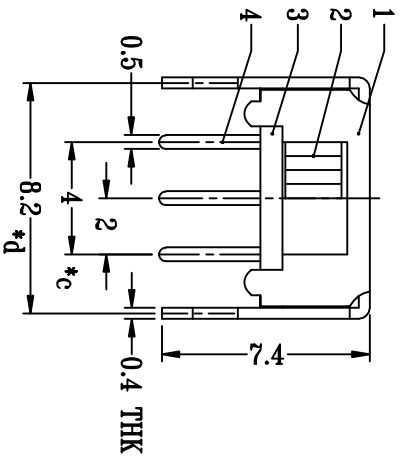
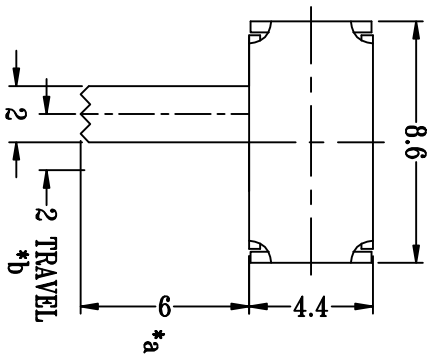

SCHEMATIC (NON-SHORTING)

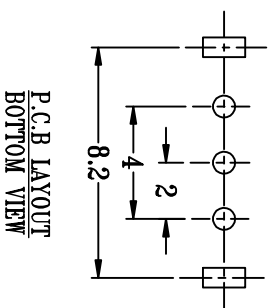

P.C.B LAYOUT  
BOTTOM VIEW

注: \*\* 表示关键尺寸 (5个)

8																			
7																			
6	SPRING PLATE	SUS	1	Ag PLATED															
5	CONTACT CLIP	PBS STRIP	1	Ag PLATED	UNTIL 1.5mm : ±0.1mm OVER 1.5mm : ±0.2mm	A	2012-8-11												
4	TERMINAL	BRASS STRIP	3	Ag PLATED															
3	BASE	PHENOLIC RESIN	1	NATURAL															
2	KNOB	POM	1	BLACK															
1	FRAME	STEEL STRIP	1	Ni PLATED															
NO.	PARTS	MATERIALS		Q'TY	FINISH														
					TOLERANCE UNLESS SPECIFIED														
					MODEL: SK12D02G6														
					SCALE: 4:1														
					DRWG NO.: LT-DR-SK12D02G6-00														
					DWN. 余丽珍														
					CHK'D 卢业创														
					APPD. 2012-8-11														