

LM2907/LM2917

Frequency to Voltage Converter

General Description

The LM2907, LM2917 series are monolithic frequency to voltage converters with a high gain op amp/comparator designed to operate a relay, lamp, or other load when the input frequency reaches or exceeds a selected rate. The tachometer uses a charge pump technique and offers frequency doubling for low ripple, full input protection in two versions (LM2907-8, LM2917-8) and its output swings to ground for a zero frequency input.

The op amp/comparator is fully compatible with the tachometer and has a floating transistor as its output. This feature allows either a ground or supply referred load of up to 50 mA. The collector may be taken above V_{CC} up to a maximum V_{CE} of 28V.

The two basic configurations offered include an 8-pin device with a *ground referenced tachometer* input and an internal connection between the tachometer output and the op amp non-inverting input. This version is well suited for single speed or frequency switching or fully buffered frequency to voltage conversion applications.

The more versatile configurations provide differential tachometer input and uncommitted op amp inputs. With this version the tachometer input may be floated and the op amp becomes suitable for active filter conditioning of the tachometer output.

Both of these configurations are available with an active shunt regulator connected across the power leads. The regulator clamps the supply such that stable frequency to voltage and frequency to current operations are possible with any supply voltage and a suitable resistor.

Advantages

- Output swings to ground for zero frequency input
- Easy to use; $V_{OUT} = f_{IN} \times V_{CC} \times R1 \times C1$

- Only one RC network provides frequency doubling
- Zener regulator on chip allows accurate and stable frequency to voltage or current conversion (LM2917)

Features

- Ground referenced tachometer input interfaces directly with variable reluctance magnetic pickups
- Op amp/comparator has floating transistor output
- 50 mA sink or source to operate relays, solenoids, meters, or LEDs
- Frequency doubling for low ripple
- Tachometer has built-in hysteresis with either differential input or ground referenced input
- Built-in zener on LM2917
- $\pm 0.3\%$ linearity typical
- Ground referenced tachometer is fully protected from damage due to swings above V_{CC} and below ground

Applications

- Over/under speed sensing
- Frequency to voltage conversion (tachometer)
- Speedometers
- Breaker point dwell meters
- Hand-held tachometer
- Speed governors
- Cruise control
- Automotive door lock control
- Clutch control
- Horn control
- Touch or sound switches

Connection Diagrams

Dual-In-Line and Small Outline Packages, Top Views

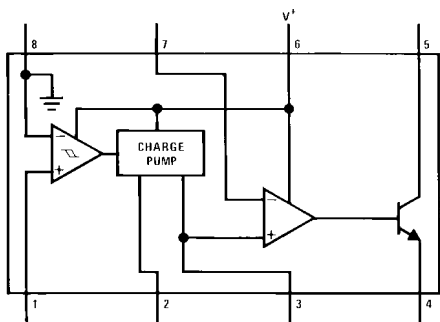

Order Number LM2907M-8 or LM2907N-8
See NS Package Number M08A or N08E

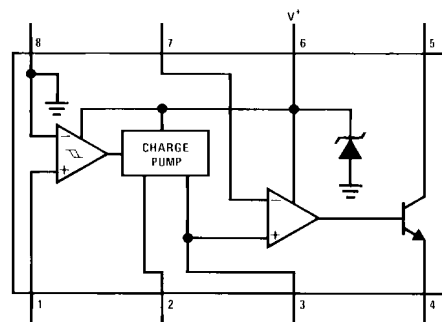

Order Number LM2917M-8 or LM2917N-8
See NS Package Number M08A or N08E

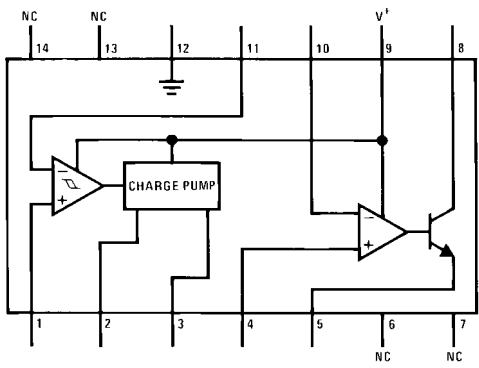

Order Number LM2907M or LM2907N
See NS Package Number M14A or N14A

794203

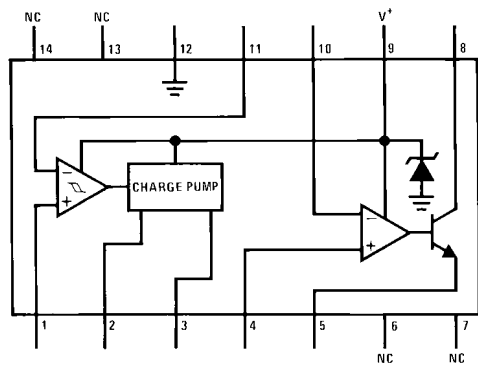

Order Number LM2917M or LM2917N
See NS Package Number M14A or N14A

794204

Ordering Information

Order Number	Package Type	Package Number	Package Marking	Supplied As
LM2907M-8	8-Pin SOIC Narrow	M08A	LM2907M-8	Rail of 95
LM2907MX-8	8-Pin SOIC Narrow	M08A	LM2907M-8	Reel of 2500
LM2907M	14-Pin SOIC Narrow	M14A	LM2907M	Rail of 55
LM2907MX	14-Pin SOIC Narrow	M14A	LM2907M	Reel of 2500
LM2907N-8	8-Pin Molded DIP	N08E	LM2907N-8	Rail of 40
LM2907N	14-Pin Molded DIP	N14A	LM2907N	Rail of 25
LM2917M-8	8-Pin SOIC Narrow	M08A	LM2917M-8	Rail of 95
LM2917MX-8	8-Pin SOIC Narrow	M08A	LM2917M-8	Reel of 2500
LM2917M	14-Pin SOIC Narrow	M14A	LM2917M	Rail of 55
LM2917MX	14-Pin SOIC Narrow	M14A	LM2917M	Reel of 2500
LM2917N-8	8-Pin Molded DIP	N08E	LM2917N-8	Rail of 40
LM2917N	14-Pin Molded DIP	N14A	LM2917N	Rail of 25

Absolute Maximum Ratings (Note 1)

If Military/Aerospace specified devices are required, please contact the National Semiconductor Sales Office/Distributors for availability and specifications.

Supply Voltage	28V	Op Amp/Comparator	0.0V to +28V
Supply Current (Zener Options)	25 mA	Power Dissipation	
Collector Voltage	28V	LM2907-8, LM2917-8	1200 mW
Differential Input Voltage		LM2907-14, LM2917-14	1580 mW
Tachometer	28V	See (Note 1)	
Op Amp/Comparator	28V	Operating Temperature Range	-40°C to +85°C
Input Voltage Range		Storage Temperature Range	-65°C to +150°C
Tachometer		Soldering Information	
LM2907-8, LM2917-8	±28V	Dual-In-Line Package	
LM2907, LM2917	0.0V to +28V	Soldering (10 seconds)	260°C
		Small Outline Package	
		Vapor Phase (60 seconds)	215°C
		Infrared (15 seconds)	220°C

Electrical Characteristics

$V_{CC} = 12 V_{DC}$, $T_A = 25^\circ C$, see test circuit

Symbol	Parameter	Conditions	Min	Typ	Max	Units
TACHOMETER						
	Input Thresholds	$V_{IN} = 250 \text{ mVp-p @ } 1 \text{ kHz}$ (Note 2)	±10	±25	±40	mV
	Hysteresis	$V_{IN} = 250 \text{ mVp-p @ } 1 \text{ kHz}$ (Note 2)		30		mV
	Offset Voltage	$V_{IN} = 250 \text{ mVp-p @ } 1 \text{ kHz}$ (Note 2)				
	LM2907/LM2917			3.5	10	mV
	LM2907-8/LM2917-8			5	15	mV
	Input Bias Current	$V_{IN} = \pm 50 \text{ mV}_{DC}$		0.1	1	μA
V_{OH}	Pin 2	$V_{IN} = +125 \text{ mV}_{DC}$ (Note 3)		8.3		V
V_{OL}	Pin 2	$V_{IN} = -125 \text{ mV}_{DC}$ (Note 3)		2.3		V
I_2, I_3	Output Current	$V_2 = V_3 = 6.0V$ (Note 4)	140	180	240	μA
I_3	Leakage Current	$I_2 = 0, V_3 = 0$			0.1	μA
K	Gain Constant	(Note 3)	0.9	1.0	1.1	
	Linearity	$f_{IN} = 1 \text{ kHz}, 5 \text{ kHz}, 10 \text{ kHz}$ (Note 5)	-1.0	0.3	+1.0	%
OP/AMP COMPARATOR						
V_{OS}		$V_{IN} = 6.0V$		3	10	mV
I_{BIAS}		$V_{IN} = 6.0V$		50	500	nA
	Input Common-Mode Voltage		0		$V_{CC} - 1.5V$	V
	Voltage Gain			200		V/mV
	Output Sink Current	$V_C = 1.0$	40	50		mA
	Output Source Current	$V_E = V_{CC} - 2.0$		10		mA
	Saturation Voltage	$I_{SINK} = 5 \text{ mA}$		0.1	0.5	V
		$I_{SINK} = 20 \text{ mA}$			1.0	V
		$I_{SINK} = 50 \text{ mA}$		1.0	1.5	V
ZENER REGULATOR						
	Regulator Voltage	$R_{DROP} = 470\Omega$		7.56		V
	Series Resistance			10.5	15	Ω
	Temperature Stability			+1		mV/°C
	Total Supply Current			3.8	6	mA

Note 1: For operation in ambient temperatures above 25°C, the device must be derated based on a 150°C maximum junction temperature and a thermal resistance of 101°C/W junction to ambient for LM2907-8 and LM2917-8, and 79°C/W junction to ambient for LM2907-14 and LM2917-14.

Note 2: Hysteresis is the sum $+V_{TH} - (-V_{TH})$, offset voltage is their difference. See test circuit.

Note 3: V_{OH} is equal to $\frac{3}{4} \times V_{CC} - 1 V_{BE}$, V_{OL} is equal to $\frac{1}{4} \times V_{CC} - 1 V_{BE}$ therefore $V_{OH} - V_{OL} = V_{CC}/2$. The difference, $V_{OH} - V_{OL}$, and the mirror gain, I_2/I_3 , are the two factors that cause the tachometer gain constant to vary from 1.0.

Note 4: Be sure when choosing the time constant $R1 \times C1$ that $R1$ is such that the maximum anticipated output voltage at pin 3 can be reached with $I_3 \times R1$. The maximum value for $R1$ is limited by the output resistance of pin 3 which is greater than 10 MΩ typically.

Note 5: Nonlinearity is defined as the deviation of V_{OUT} (@ pin 3) for $f_{IN} = 5$ kHz from a straight line defined by the V_{OUT} @ 1 kHz and V_{OUT} @ 10 kHz. $C1 = 1000$ pF, $R1 = 68k$ and $C2 = 0.22$ mFd.

Test Circuit and Waveform

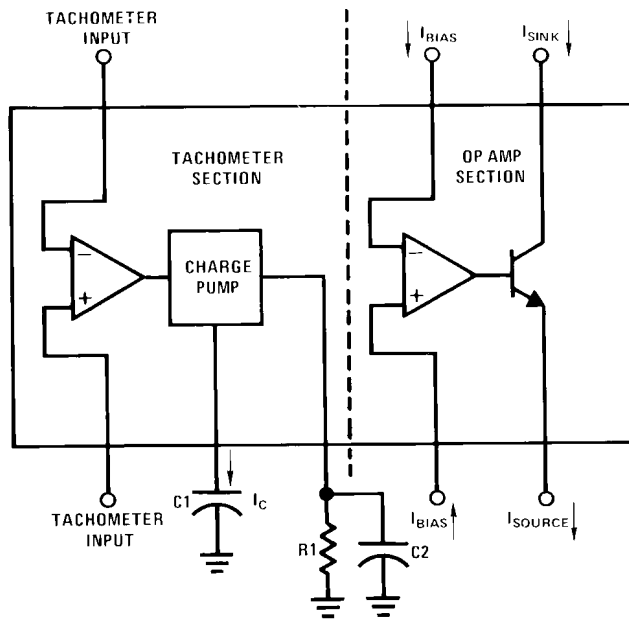

794206

Tachometer Input Threshold Measurement

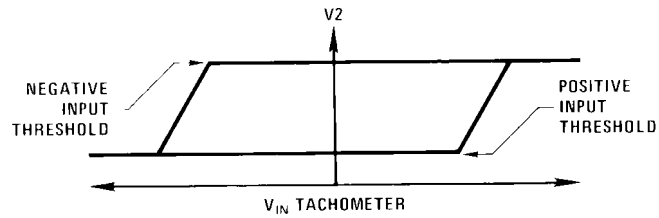

794207

Typical Performance Characteristics

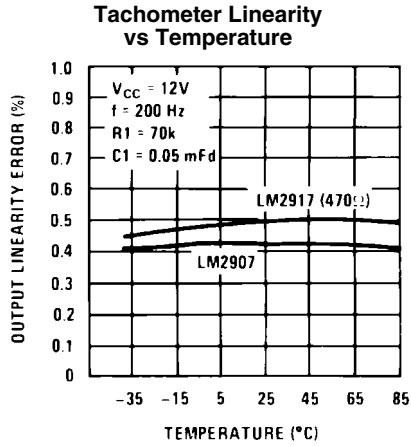

794246

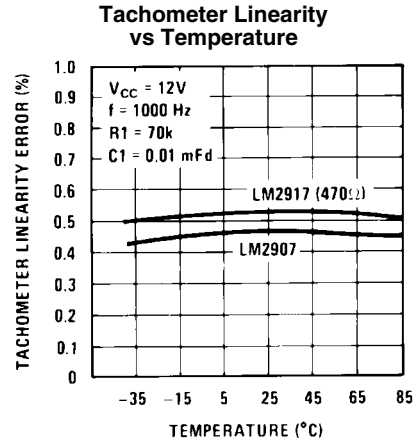

794247

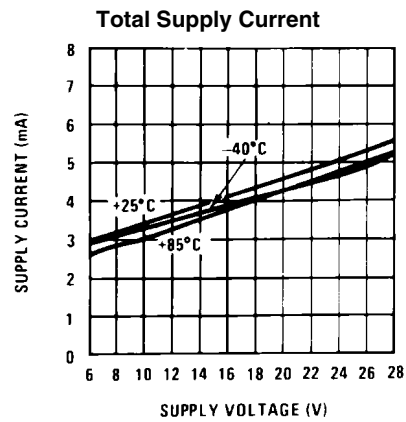

794240

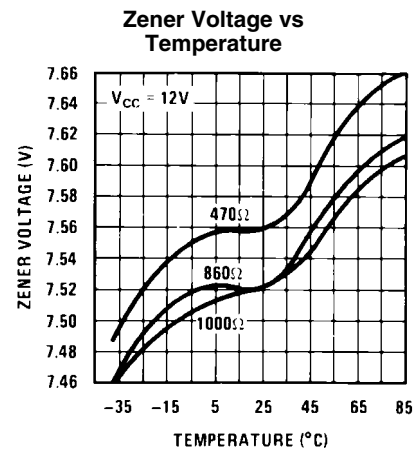

794241

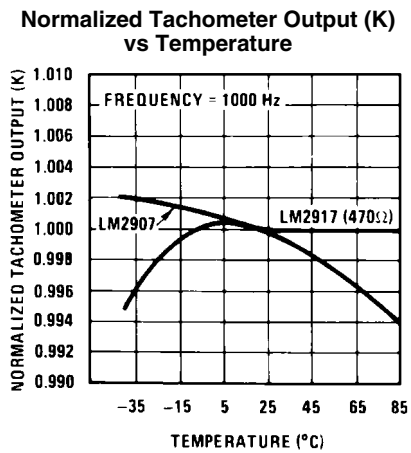

794242

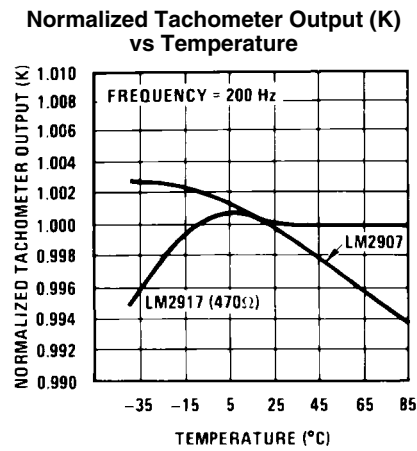

794243

Tachometer Currents I_2 and I_3 vs Supply Voltage

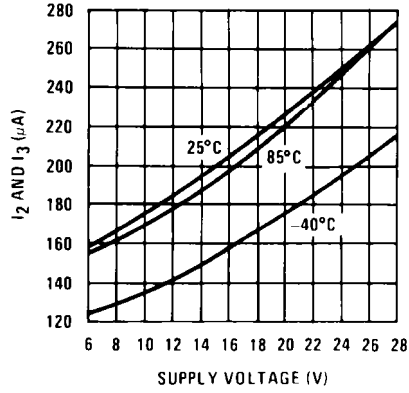

794244

Tachometer Currents I_2 and I_3 vs Temperature

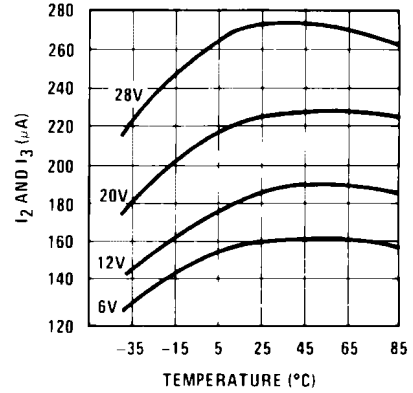

794245

Tachometer Linearity vs R1

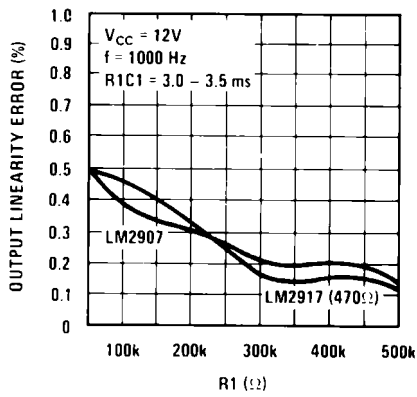

794248

Tachometer Input Hysteresis vs Temperature

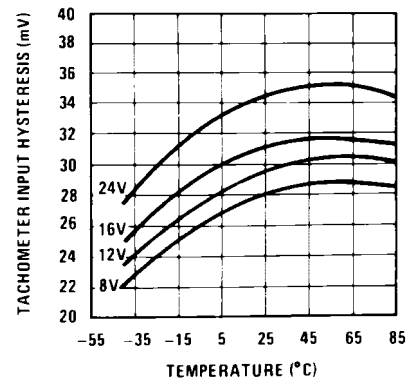

794249

Op Amp Output Transistor Characteristics

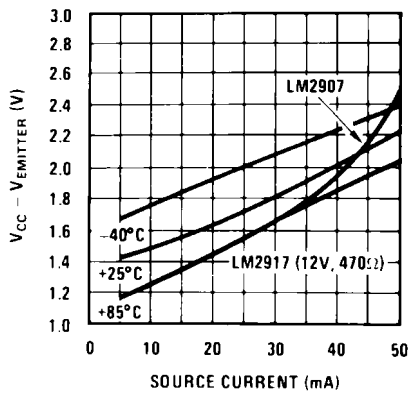

794250

Op Amp Output Transistor Characteristics

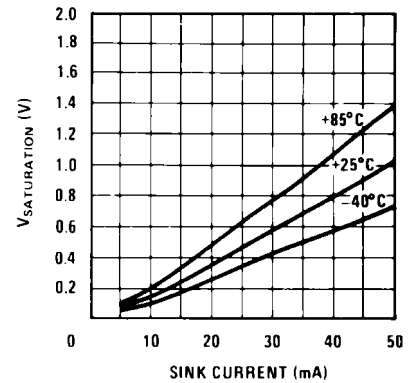

794251

Applications Information

The LM2907 series of tachometer circuits is designed for minimum external part count applications and maximum versatility. In order to fully exploit its features and advantages let's examine its theory of operation. The first stage of operation is a differential amplifier driving a positive feedback flip-flop circuit. The input threshold voltage is the amount of differential input voltage at which the output of this stage changes state. Two options (LM2907-8, LM2917-8) have one input internally grounded so that an input signal must swing above and below ground and exceed the input thresholds to produce an output. This is offered specifically for magnetic variable reluctance pickups which typically provide a single-ended ac output. This single input is also fully protected against voltage swings to $\pm 28V$, which are easily attained with these types of pickups.

The differential input options (LM2907, LM2917) give the user the option of setting his own input switching level and still have the hysteresis around that level for excellent noise rejection in any application. Of course in order to allow the inputs to attain common-mode voltages above ground, input protection is removed and neither input should be taken outside the limits of the supply voltage being used. It is very important that an input not go below ground without some resistance in its lead to limit the current that will then flow in the epi-substrate diode.

Following the input stage is the charge pump where the input frequency is converted to a dc voltage. To do this requires one timing capacitor, one output resistor, and an integrating or filter capacitor. When the input stage changes state (due to a suitable zero crossing or differential voltage on the input) the timing capacitor is either charged or discharged linearly between two voltages whose difference is $V_{CC}/2$. Then in one half cycle of the input frequency or a time equal to $1/2 f_{IN}$ the change in charge on the timing capacitor is equal to $V_{CC}/2 \times C1$. The average amount of current pumped into or out of the capacitor then is:

$$\frac{\Delta Q}{T} = i_{c(AVG)} = C1 \times \frac{V_{CC}}{2} \times (2f_{IN}) = V_{CC} \times f_{IN} \times C1$$

The output circuit mirrors this current very accurately into the load resistor R1, connected to ground, such that if the pulses of current are integrated with a filter capacitor, then $V_O = i_c \times R1$, and the total conversion equation becomes:

$$V_O = V_{CC} \times f_{IN} \times C1 \times R1 \times K$$

Where K is the gain constant—typically 1.0.

The size of C2 is dependent only on the amount of ripple voltage allowable and the required response time.

CHOOSING R1 AND C1

There are some limitations on the choice of R1 and C1 which should be considered for optimum performance. The timing capacitor also provides internal compensation for the charge pump and should be kept larger than 500 pF for very accurate operation. Smaller values can cause an error current on R1, especially at low temperatures. Several considerations must be met when choosing R1. The output current at pin 3 is internally fixed and therefore $V_O/R1$ must be less than or equal to this value. If R1 is too large, it can become a significant fraction of the output impedance at pin 3 which degrades linearity. Also output ripple voltage must be considered and the size of C2 is affected by R1. An expression that describes the ripple content on pin 3 for a single R1C2 combination is:

$$V_{RIPPLE} = \frac{V_{CC}}{2} \times \frac{C1}{C2} \times \left(1 - \frac{V_{CC} \times f_{IN} \times C1}{I_2}\right) \text{pk-pk}$$

It appears R1 can be chosen independent of ripple, however response time, or the time it takes V_{OUT} to stabilize at a new voltage increases as the size of C2 increases, so a compromise between ripple, response time, and linearity must be chosen carefully.

As a final consideration, the maximum attainable input frequency is determined by V_{CC} , C1 and I_2 :

$$f_{MAX} = \frac{I_2}{C1 \times V_{CC}}$$

USING ZENER REGULATED OPTIONS (LM2917)

For those applications where an output voltage or current must be obtained independent of supply voltage variations, the LM2917 is offered. The most important consideration in choosing a dropping resistor from the unregulated supply to the device is that the tachometer and op amp circuitry alone require about 3 mA at the voltage level provided by the zener. At low supply voltages there must be some current flowing in the resistor above the 3 mA circuit current to operate the regulator. As an example, if the raw supply varies from 9V to 16V, a resistance of 470 Ω will minimize the zener voltage variation to 160 mV. If the resistance goes under 400 Ω or over 600 Ω the zener variation quickly rises above 200 mV for the same input variation.

Typical Applications

Minimum Component Tachometer

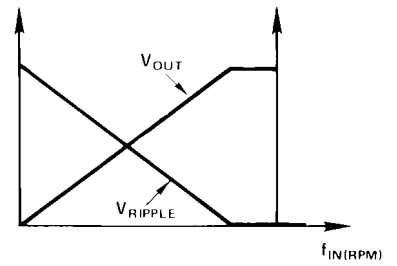
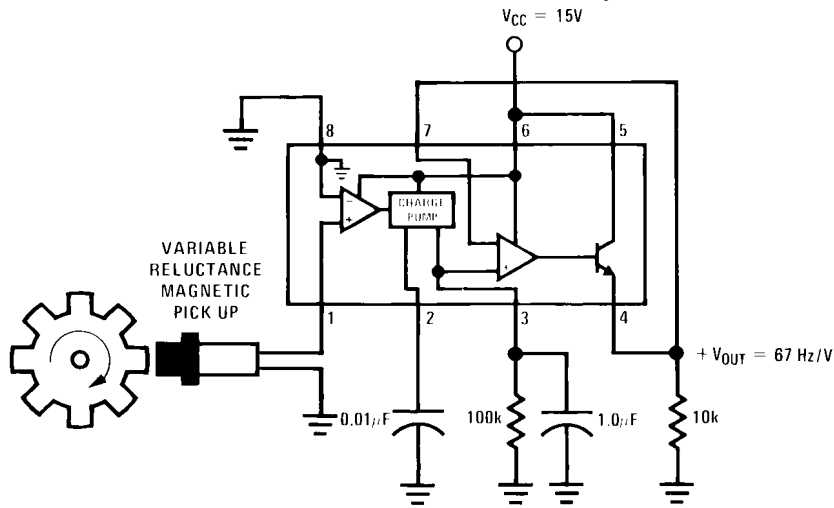

794208

"Speed Switch", Load is Energized when $f_{IN} \geq (1 / (2RC))$

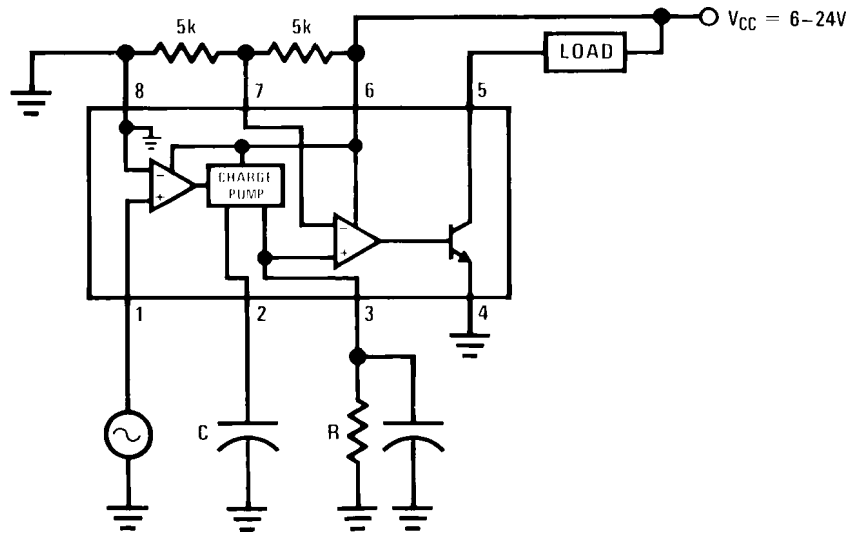

794209

Zener Regulated Frequency to Voltage Converter

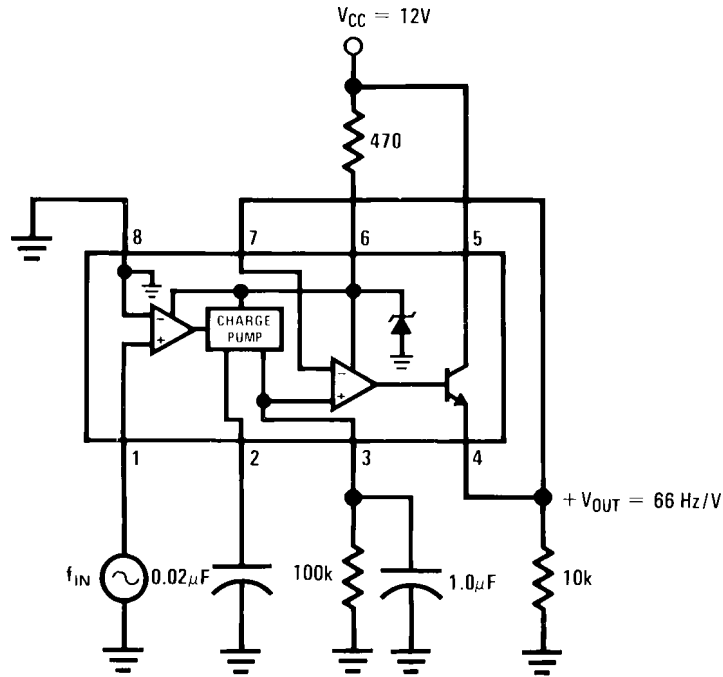

794210

Breaker Point Dwell Meter

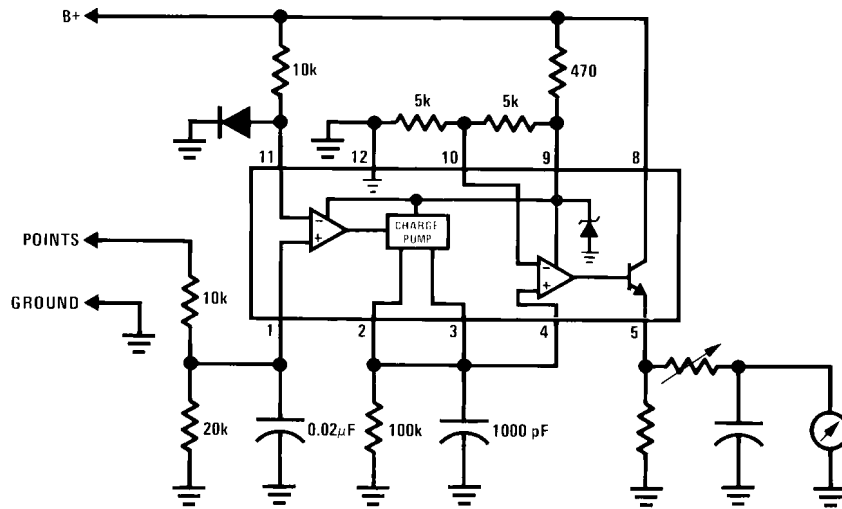

794211

Voltage Driven Meter Indicating Engine RPM
 $V_o = 6V @ 400 \text{ Hz or } 6000 \text{ ERPM (8 Cylinder Engine)}$

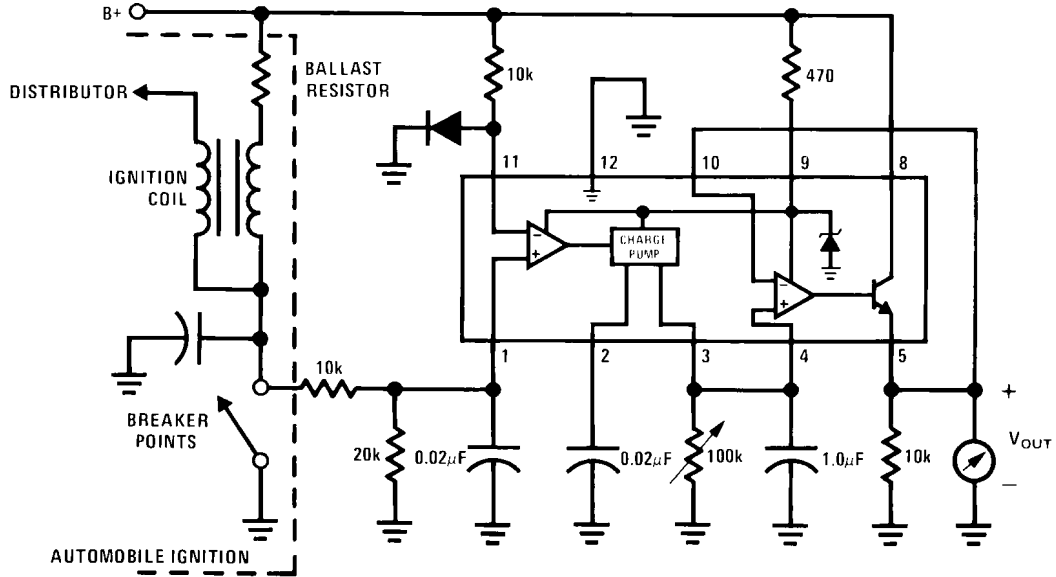

794212

Current Driven Meter Indicating Engine RPM
 $I_o = 10 \text{ mA} @ 300 \text{ Hz or } 6000 \text{ ERPM (6 Cylinder Engine)}$

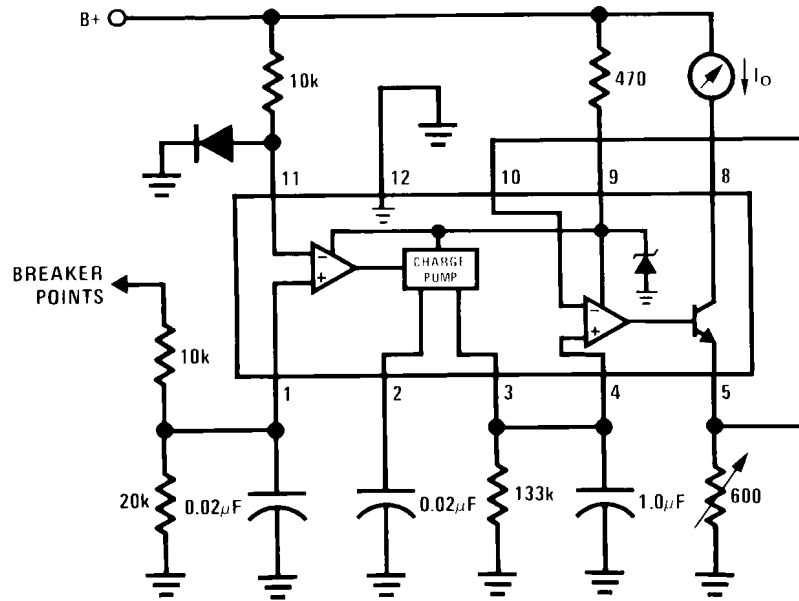

794213

Capacitance Meter
 $V_{OUT} = 1V-10V$ for $C_X = 0.01$ to 0.1 mFd
 (R = 111k)

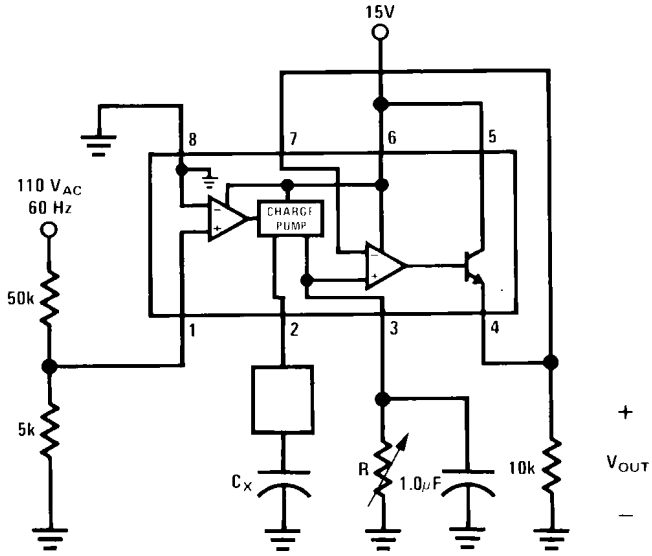

794214

Two-Wire Remote Speed Switch

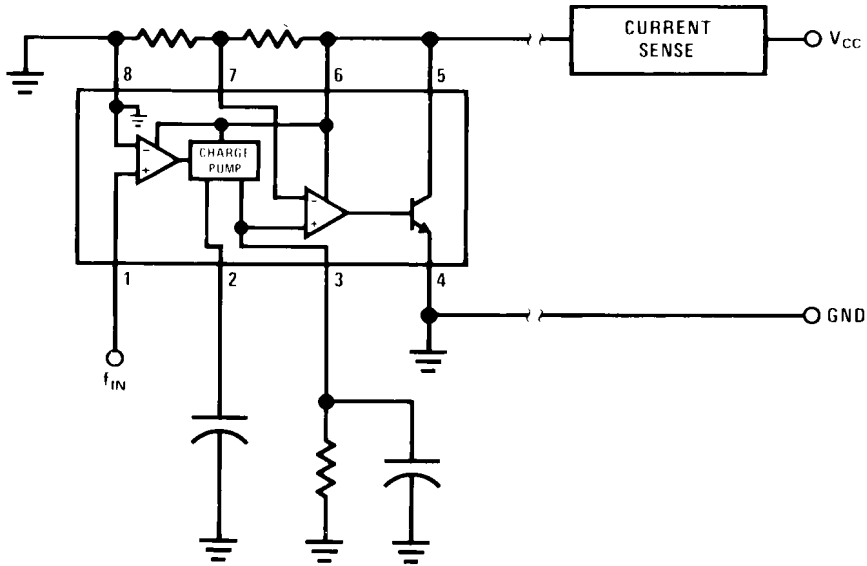

794215

100 Cycle Delay Switch

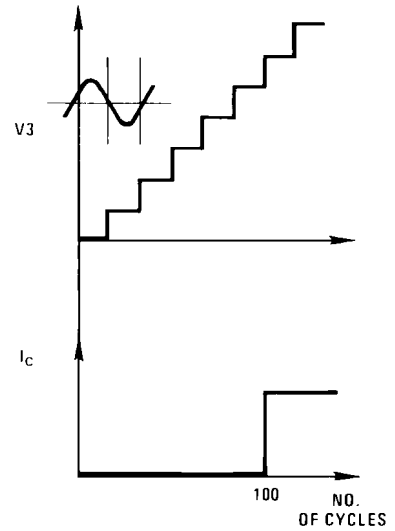
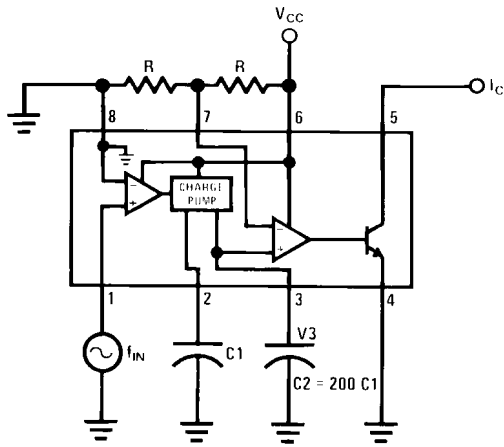

794216

V_3 steps up in voltage by the amount $\frac{V_{CC} \times C_1}{C_2}$
for each complete input cycle (2 zero crossings)

Example:
if $C_2 = 200 C_1$ after 100 consecutive input cycles.
 $V_3 = 1/2 V_{CC}$

Variable Reluctance Magnetic Pickup Buffer Circuits

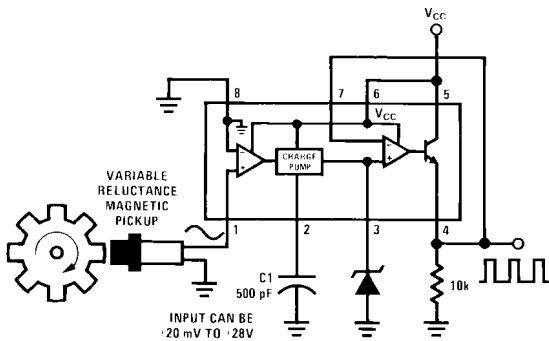

794239

Precision two-shot output frequency equals twice input frequency.

$$\text{Pulse width} = \frac{V_{CC} C_1}{2 I_2}$$

Pulse height = V_{ZENER}

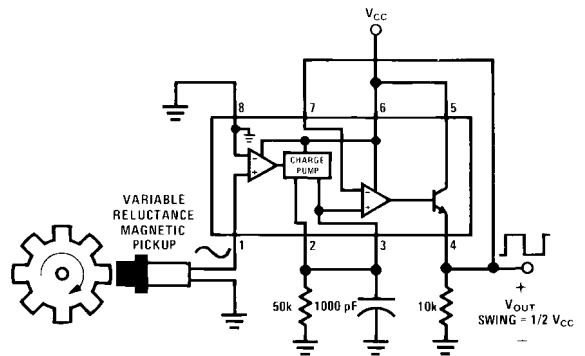

794217

Finger Touch or Contact Switch

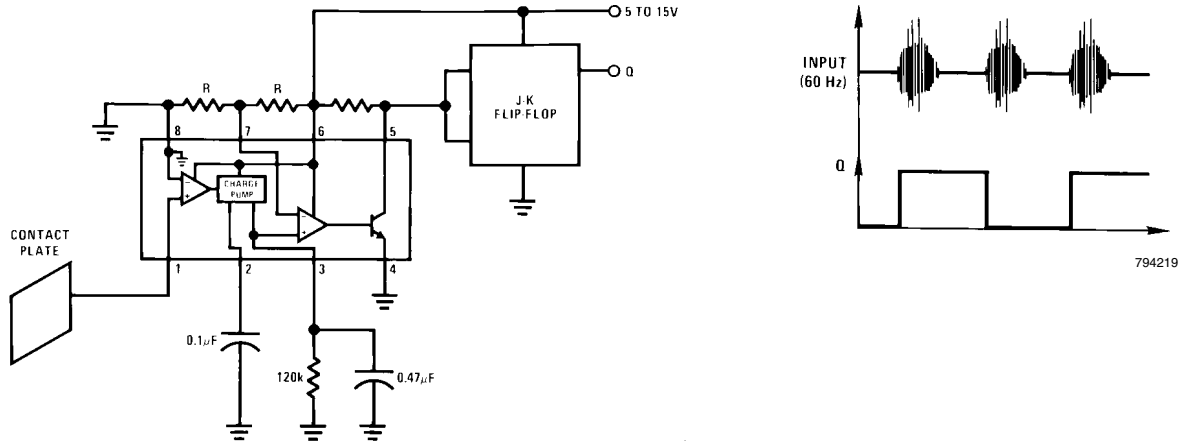

794218

Flashing LED Indicates Overspeed

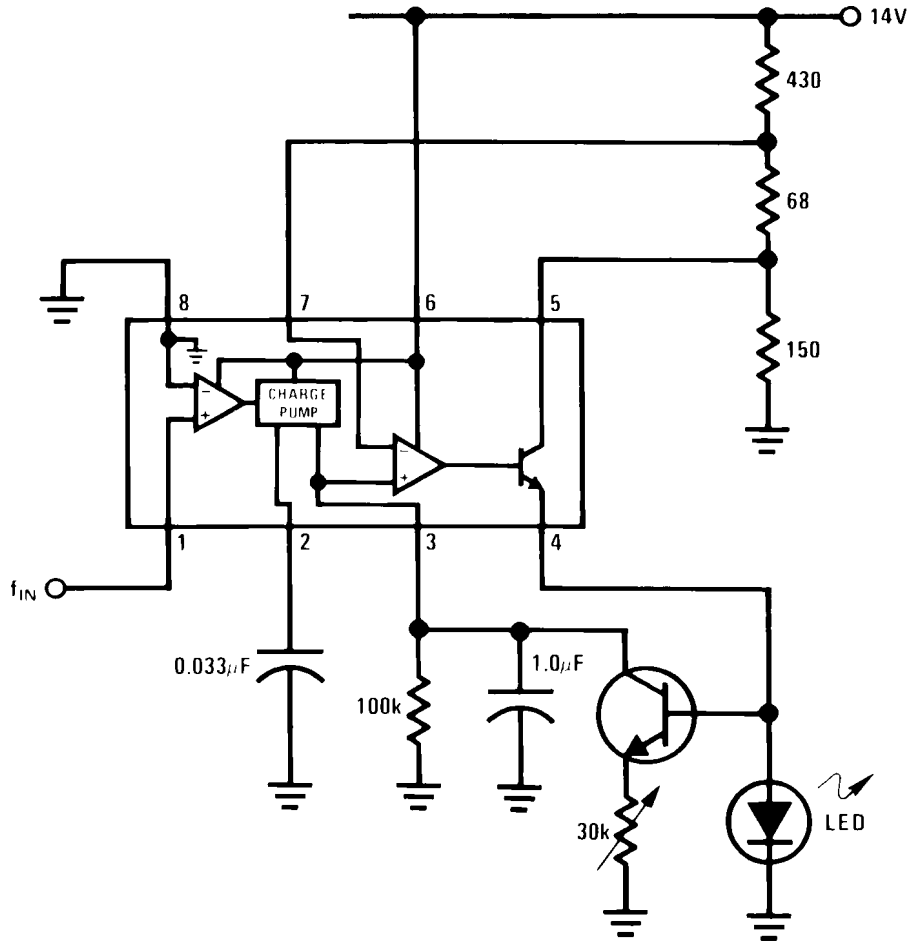

794220

Flashing begins when $f_{IN} \geq 100$ Hz.
Flash rate increases with input frequency increase beyond trip point.

Frequency to Voltage Converter with 2 Pole Butterworth Filter to Reduce Ripple

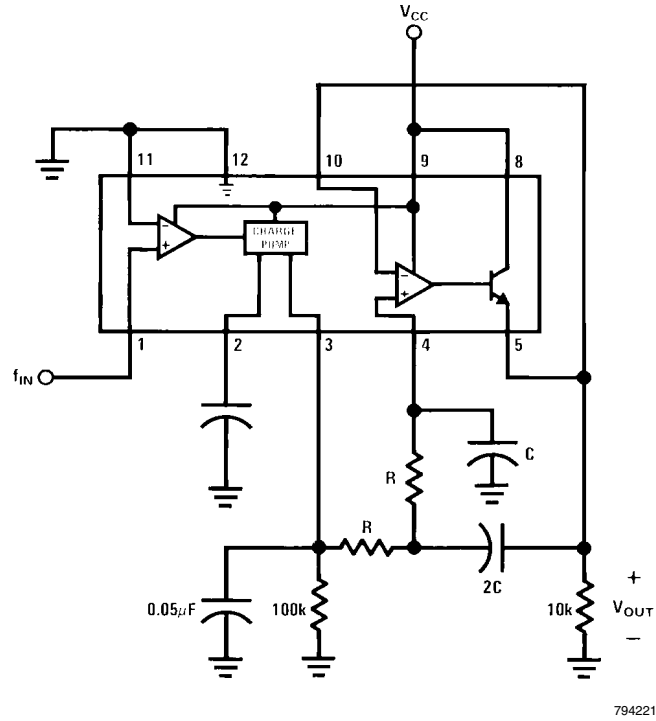

$$f_{POLE} = \frac{0.707}{2\pi RC}$$

$$\tau_{RESPONSE} = \frac{2.57}{2\pi f_{POLE}}$$

Overspeed Latch

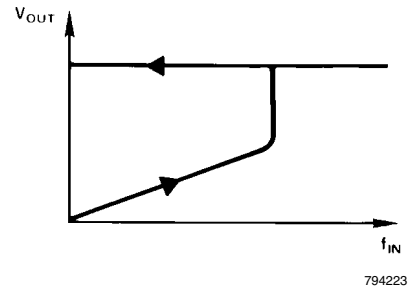
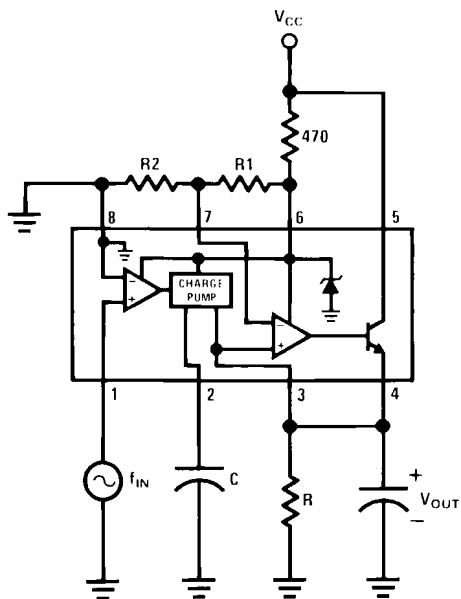

Output latches when

$$f_{IN} = \frac{R2}{R1 + R2} \frac{1}{RC}$$

Reset by removing V_{CC} .

Some Frequency Switch Applications May Require Hysteresis in the Comparator Function Which can be Implemented in Several Ways

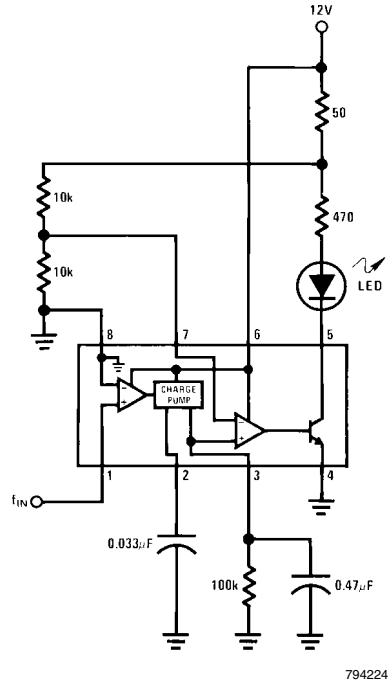

794224

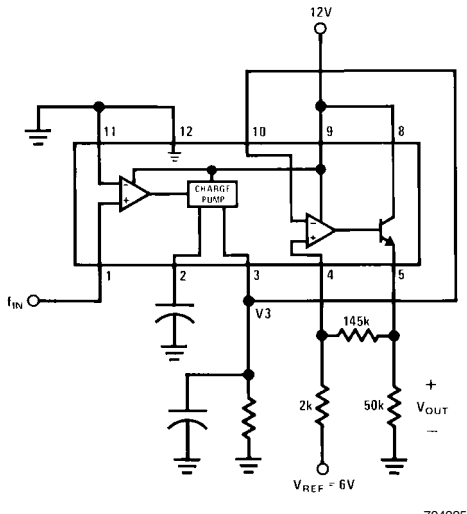

794225

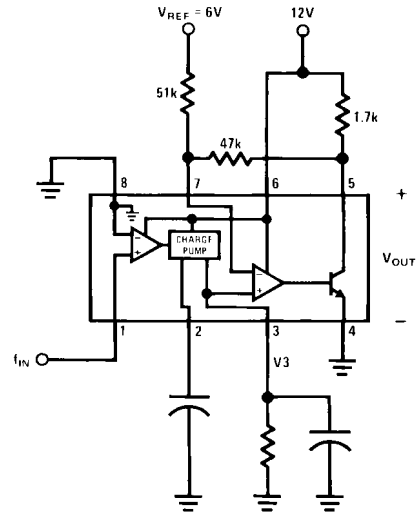

794226

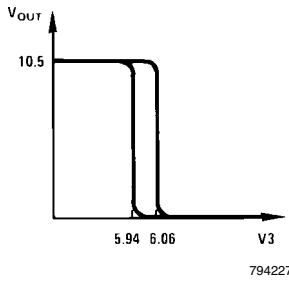

794227

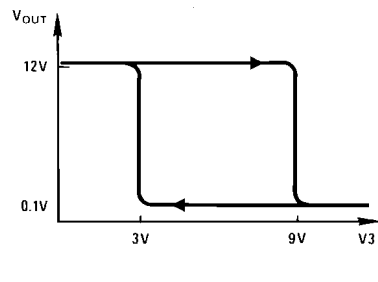

794228

Changing the Output Voltage for an Input Frequency of Zero

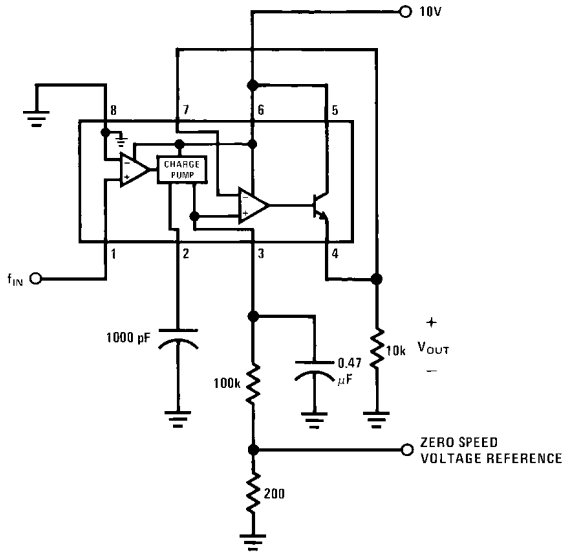

794229

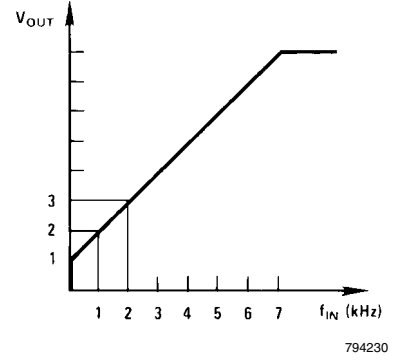

794230

Changing Tachometer Gain Curve or Clamping the Minimum Output Voltage

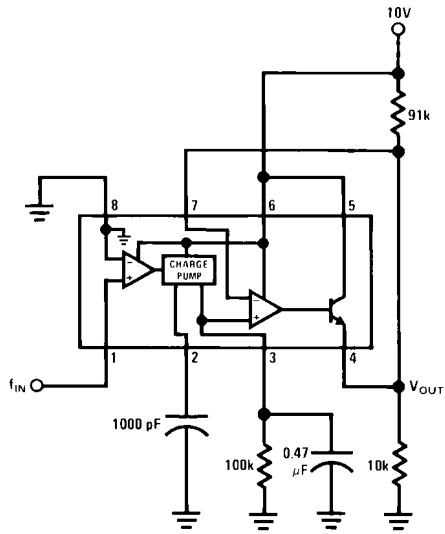

794231

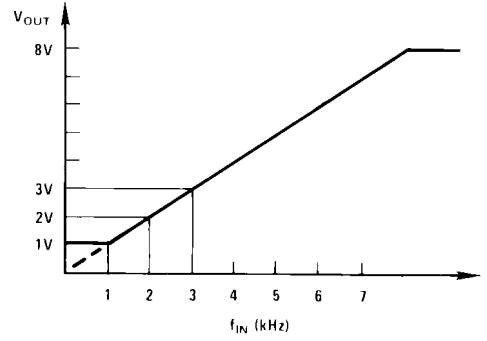

794232

Anti-Skid Circuit Functions

"Select-Low" Circuit

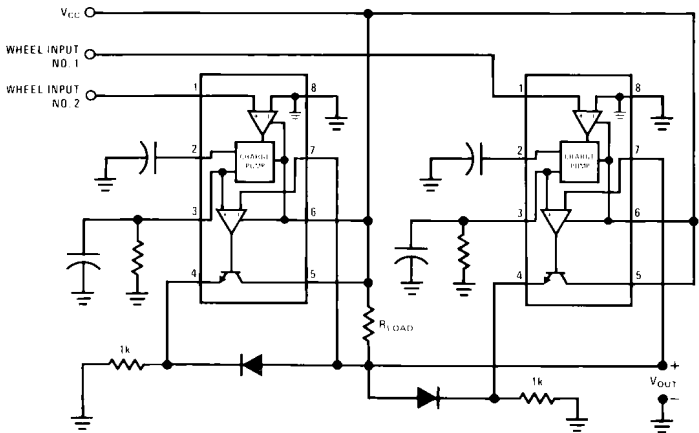

794233

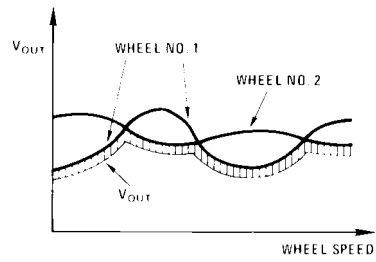

794234

V_{OUT} is proportional to the lower of the two input wheel speeds.

"Select-High" Circuit

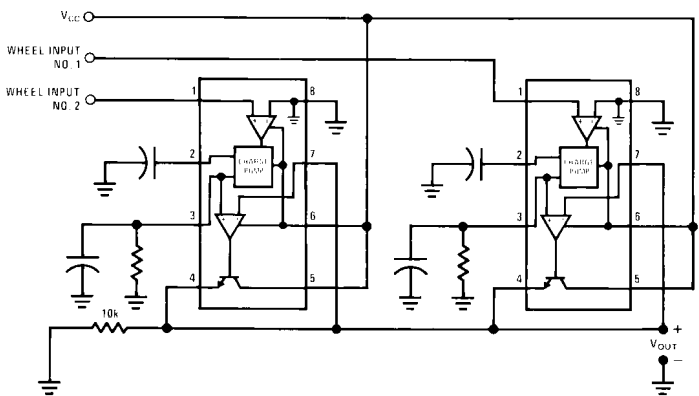

794235

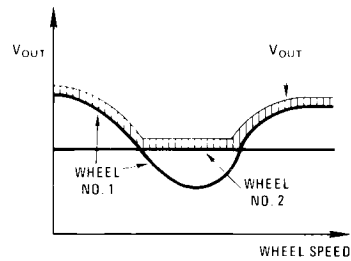

794236

V_{OUT} is proportional to the higher of the two input wheel speeds.

"Select-Average" Circuit

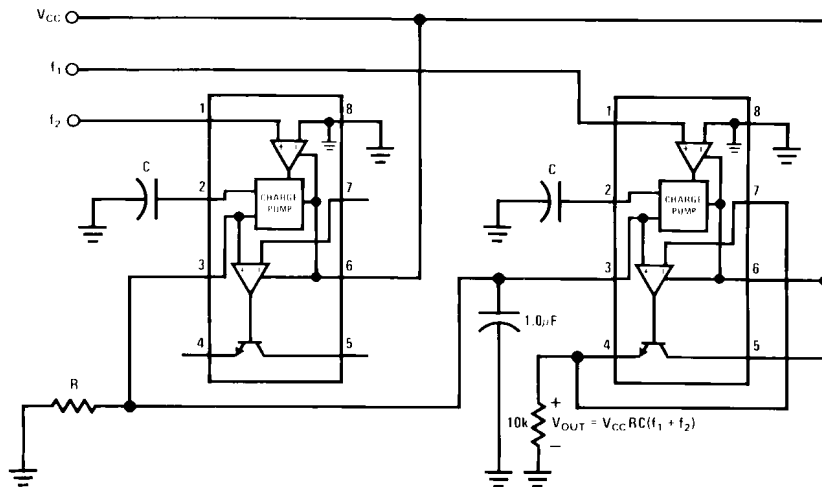

794237

Equivalent Schematic Diagram

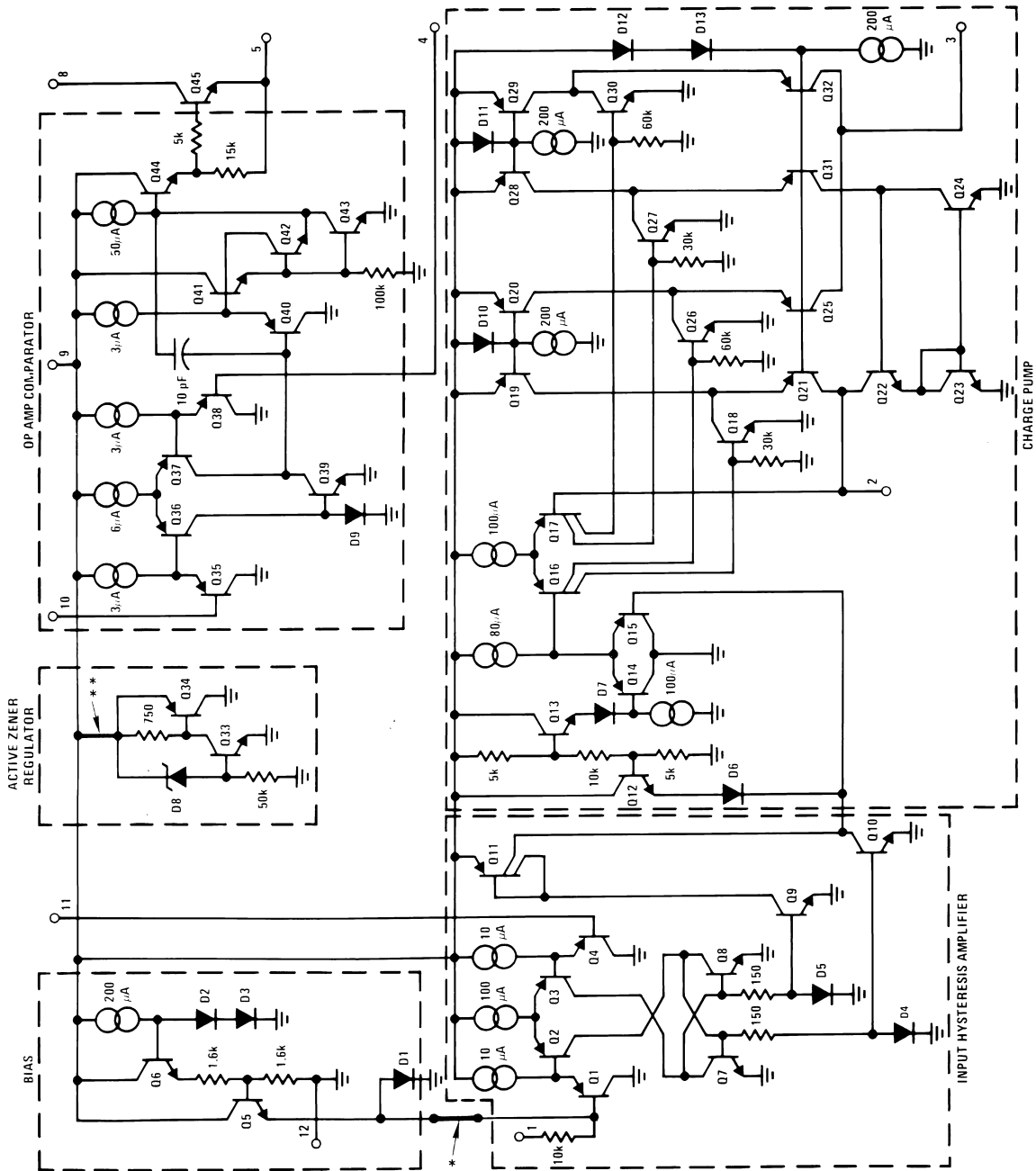

794238

*This connection made on LM2907-8 and LM2917-8 only.
 **This connection made on LM2917 and LM2917-8 only.

Physical Dimensions inches (millimeters) unless otherwise noted

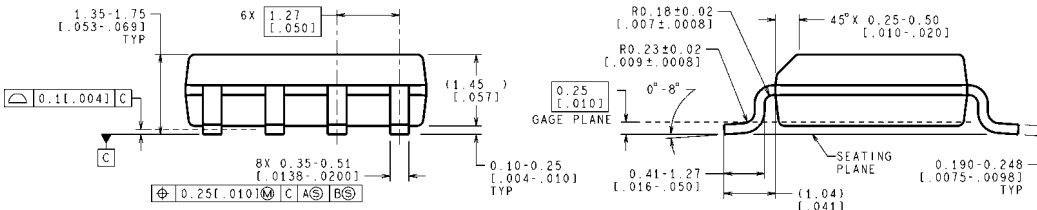
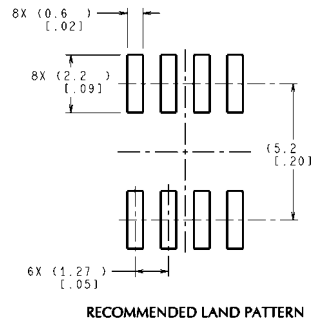
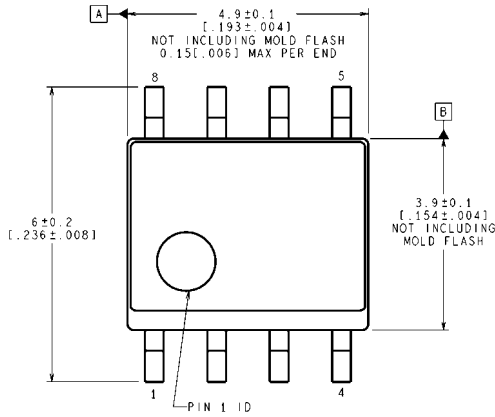

CONTROLLING DIMENSION IS MILLIMETER
 VALUES IN [] ARE INCHES
 DIMENSIONS IN () FOR REFERENCE ONLY

8-Lead (0.150 Wide) Molded Small Outline Package, JEDEC
Order Number LM2907M-8 or LM2917M-8
NS Package Number M08A

M08A (Rev L)

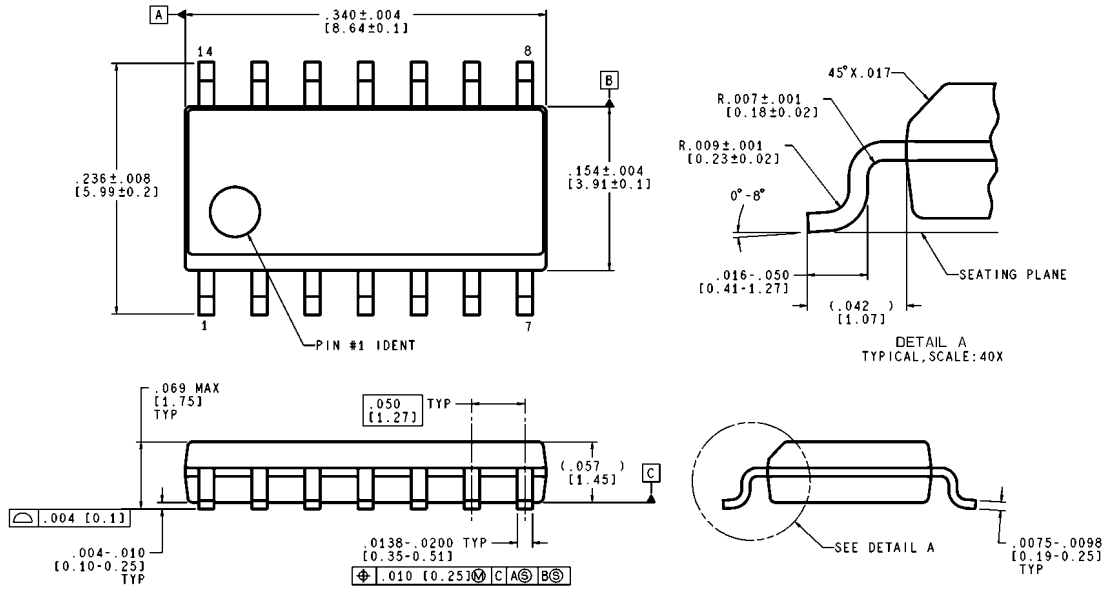

CONTROLLING DIMENSION IS INCH
VALUES IN [] ARE MILLIMETERS

M14A (REV J)

Molded SO Package (M)
Order Number LM2907M or LM2917M
NS Package Number M14A

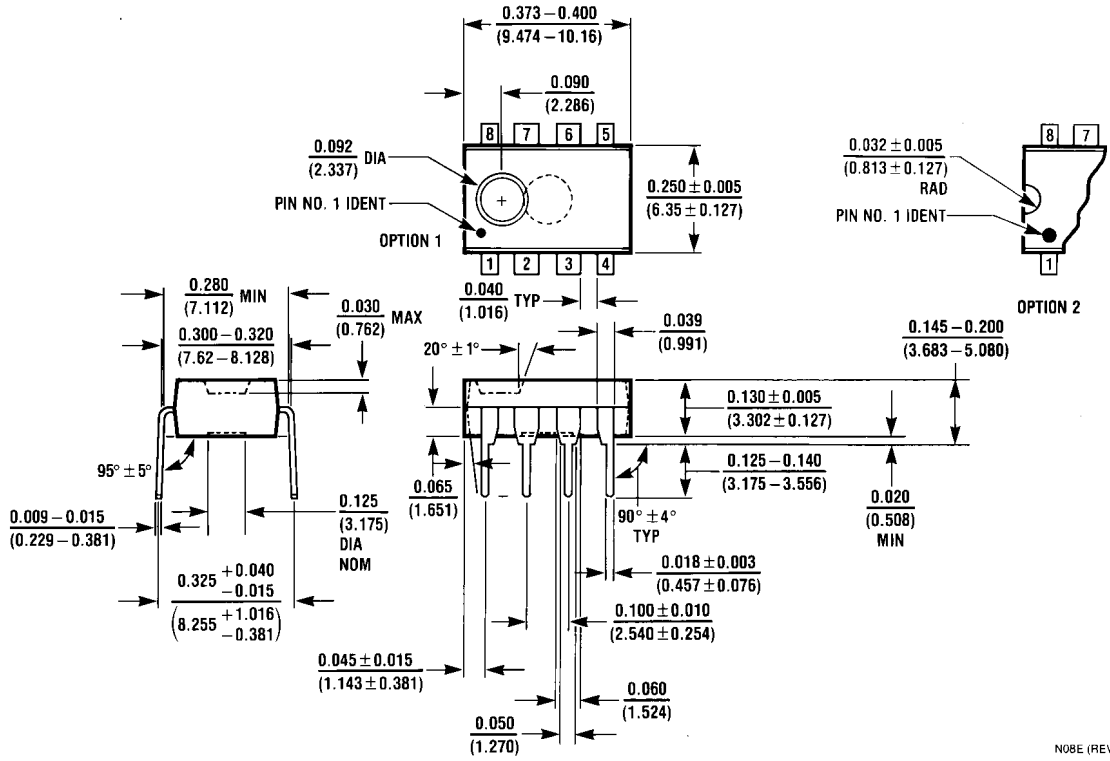

Molded Dual-In-Line Package (N)
Order Number LM2907N-8 or LM2917N-8
NS Package Number N08E

N08E (REV F)

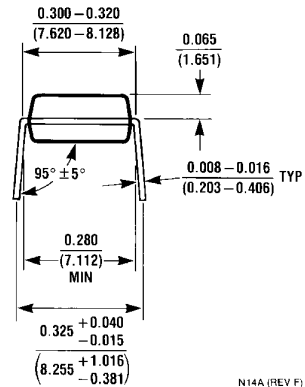
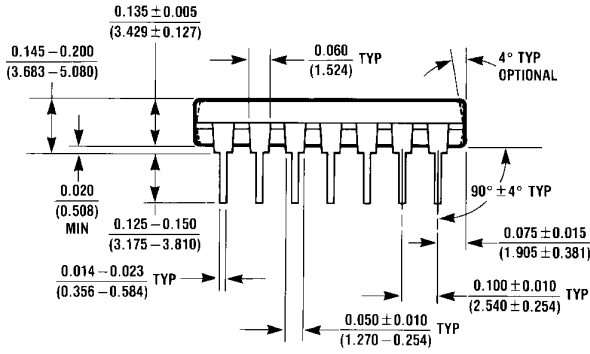
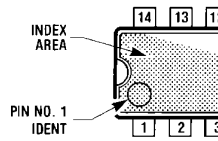
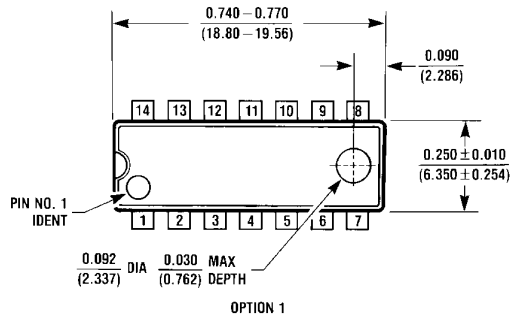

N14A (REV F)

Molded Dual-In-Line Package (N)
Order Number LM2907N or LM2917N
NS Package Number N14A

Notes

For more National Semiconductor product information and proven design tools, visit the following Web sites at:

Products		Design Support	
Amplifiers	www.national.com/amplifiers	WEBENCH® Tools	www.national.com/webench
Audio	www.national.com/audio	App Notes	www.national.com/appnotes
Clock and Timing	www.national.com/timing	Reference Designs	www.national.com/refdesigns
Data Converters	www.national.com/adc	Samples	www.national.com/samples
Interface	www.national.com/interface	Eval Boards	www.national.com/evalboards
LVDS	www.national.com/lvds	Packaging	www.national.com/packaging
Power Management	www.national.com/power	Green Compliance	www.national.com/quality/green
Switching Regulators	www.national.com/switchers	Distributors	www.national.com/contacts
LDOs	www.national.com/ldo	Quality and Reliability	www.national.com/quality
LED Lighting	www.national.com/led	Feedback/Support	www.national.com/feedback
Voltage Reference	www.national.com/vref	Design Made Easy	www.national.com/easy
PowerWise® Solutions	www.national.com/powerwise	Solutions	www.national.com/solutions
Serial Digital Interface (SDI)	www.national.com/sdi	Mil/Aero	www.national.com/milaero
Temperature Sensors	www.national.com/tempsensors	Solar Magic®	www.national.com/solarmagic
Wireless (PLL/VCO)	www.national.com/wireless	Analog University®	www.national.com/AU

THE CONTENTS OF THIS DOCUMENT ARE PROVIDED IN CONNECTION WITH NATIONAL SEMICONDUCTOR CORPORATION ("NATIONAL") PRODUCTS. NATIONAL MAKES NO REPRESENTATIONS OR WARRANTIES WITH RESPECT TO THE ACCURACY OR COMPLETENESS OF THE CONTENTS OF THIS PUBLICATION AND RESERVES THE RIGHT TO MAKE CHANGES TO SPECIFICATIONS AND PRODUCT DESCRIPTIONS AT ANY TIME WITHOUT NOTICE. NO LICENSE, WHETHER EXPRESS, IMPLIED, ARISING BY ESTOPPEL OR OTHERWISE, TO ANY INTELLECTUAL PROPERTY RIGHTS IS GRANTED BY THIS DOCUMENT.

TESTING AND OTHER QUALITY CONTROLS ARE USED TO THE EXTENT NATIONAL DEEMS NECESSARY TO SUPPORT NATIONAL'S PRODUCT WARRANTY. EXCEPT WHERE MANDATED BY GOVERNMENT REQUIREMENTS, TESTING OF ALL PARAMETERS OF EACH PRODUCT IS NOT NECESSARILY PERFORMED. NATIONAL ASSUMES NO LIABILITY FOR APPLICATIONS ASSISTANCE OR BUYER PRODUCT DESIGN. BUYERS ARE RESPONSIBLE FOR THEIR PRODUCTS AND APPLICATIONS USING NATIONAL COMPONENTS. PRIOR TO USING OR DISTRIBUTING ANY PRODUCTS THAT INCLUDE NATIONAL COMPONENTS, BUYERS SHOULD PROVIDE ADEQUATE DESIGN, TESTING AND OPERATING SAFEGUARDS.

EXCEPT AS PROVIDED IN NATIONAL'S TERMS AND CONDITIONS OF SALE FOR SUCH PRODUCTS, NATIONAL ASSUMES NO LIABILITY WHATSOEVER, AND NATIONAL DISCLAIMS ANY EXPRESS OR IMPLIED WARRANTY RELATING TO THE SALE AND/OR USE OF NATIONAL PRODUCTS INCLUDING LIABILITY OR WARRANTIES RELATING TO FITNESS FOR A PARTICULAR PURPOSE, MERCHANTABILITY, OR INFRINGEMENT OF ANY PATENT, COPYRIGHT OR OTHER INTELLECTUAL PROPERTY RIGHT.

LIFE SUPPORT POLICY

NATIONAL'S PRODUCTS ARE NOT AUTHORIZED FOR USE AS CRITICAL COMPONENTS IN LIFE SUPPORT DEVICES OR SYSTEMS WITHOUT THE EXPRESS PRIOR WRITTEN APPROVAL OF THE CHIEF EXECUTIVE OFFICER AND GENERAL COUNSEL OF NATIONAL SEMICONDUCTOR CORPORATION. As used herein:

Life support devices or systems are devices which (a) are intended for surgical implant into the body, or (b) support or sustain life and whose failure to perform when properly used in accordance with instructions for use provided in the labeling can be reasonably expected to result in a significant injury to the user. A critical component is any component in a life support device or system whose failure to perform can be reasonably expected to cause the failure of the life support device or system or to affect its safety or effectiveness.

National Semiconductor and the National Semiconductor logo are registered trademarks of National Semiconductor Corporation. All other brand or product names may be trademarks or registered trademarks of their respective holders.

Copyright© 2008 National Semiconductor Corporation

For the most current product information visit us at www.national.com

